

Automation Equipment



- SpeedFeeders for quick and easy handling of sheet metal blanks and formed components in presses.
- Transfer systems for automation of presses with multiple press tools/transfer tooling.
- Blank destackers for separation, lubrication and positioning of blanks before feeding into presses.
- Robots for various ancillary handling operations, before, during and after the production process.

SpeedFeeders

- Developed specifically for handling sheet metal parts in presses
- Fast action linear-axis servomotor driven movements for simple programming relating to the press tool/press bed
- Handling of loads from 5 kg to 240 kg
- Mounting directly on the press or on a separate floor stand



SpeedFeeder 40/60 T2



SpeedFeeder 120 T2

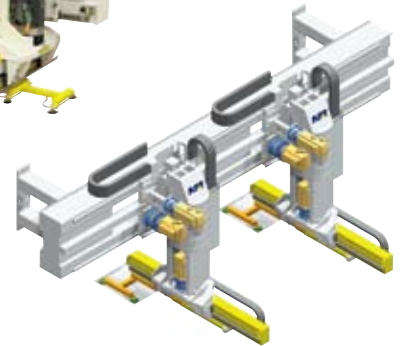

SpeedFeeder 40/60 2x

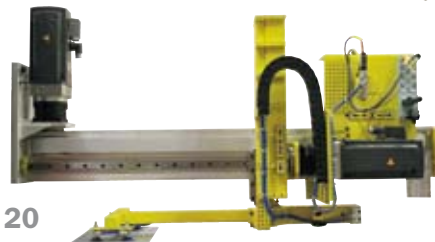

Linear Feeder CD 20

Transfer Systems

- Handling of parts in presses with multi operation tools/transfer tooling
- Lifting capacity up to 240 kg
- Simple installation on the press without mechanical transmission power through the press frame

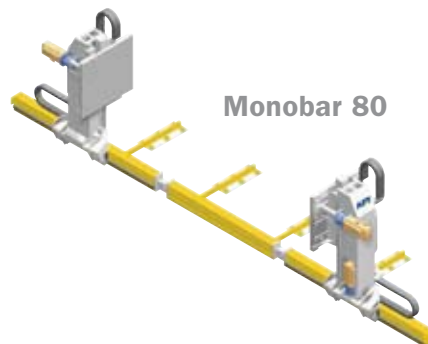

Monobar 80

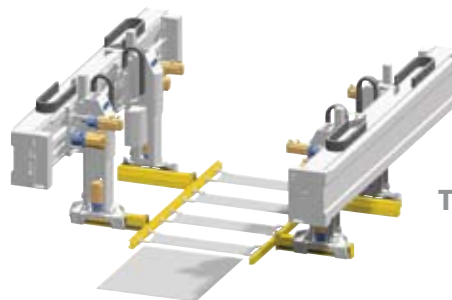

Transfer SpeedFeeder 40 4x

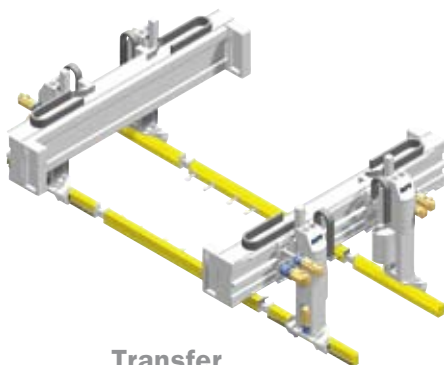

Transfer



Monobar 40

Blank Destackers

High Speed Destacker

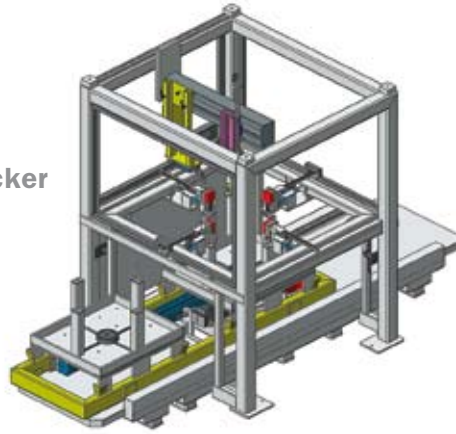

- Storing of blank stacks with easy loading of material in one or two magazines. Twin magazines allow for continuous feeding when loading a new stack
- Safe separation of blanks, including non-magnetic material
- Double blank detection with possibility of automatic ejection of double blanks
- Blank lubrication with a variety of options
- Positioning of blank for subsequent loading into the tool
- Handles rectangular or contoured blanks



Centering table

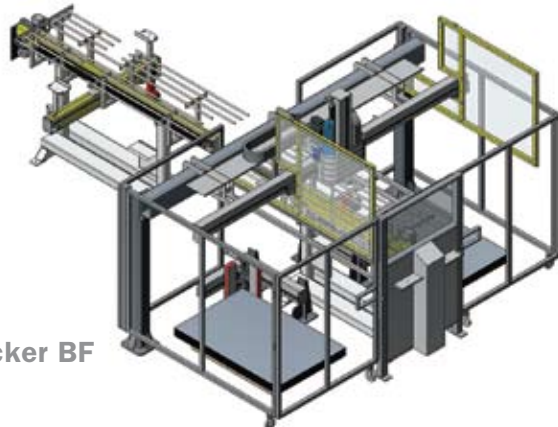

Blank Destacker BF

Robots



Press Robot IRB

- Complement to AP&T's other blank handling program
- Freely programmable in 6 axes
- Machining of parts
- Stacking or destacking functions

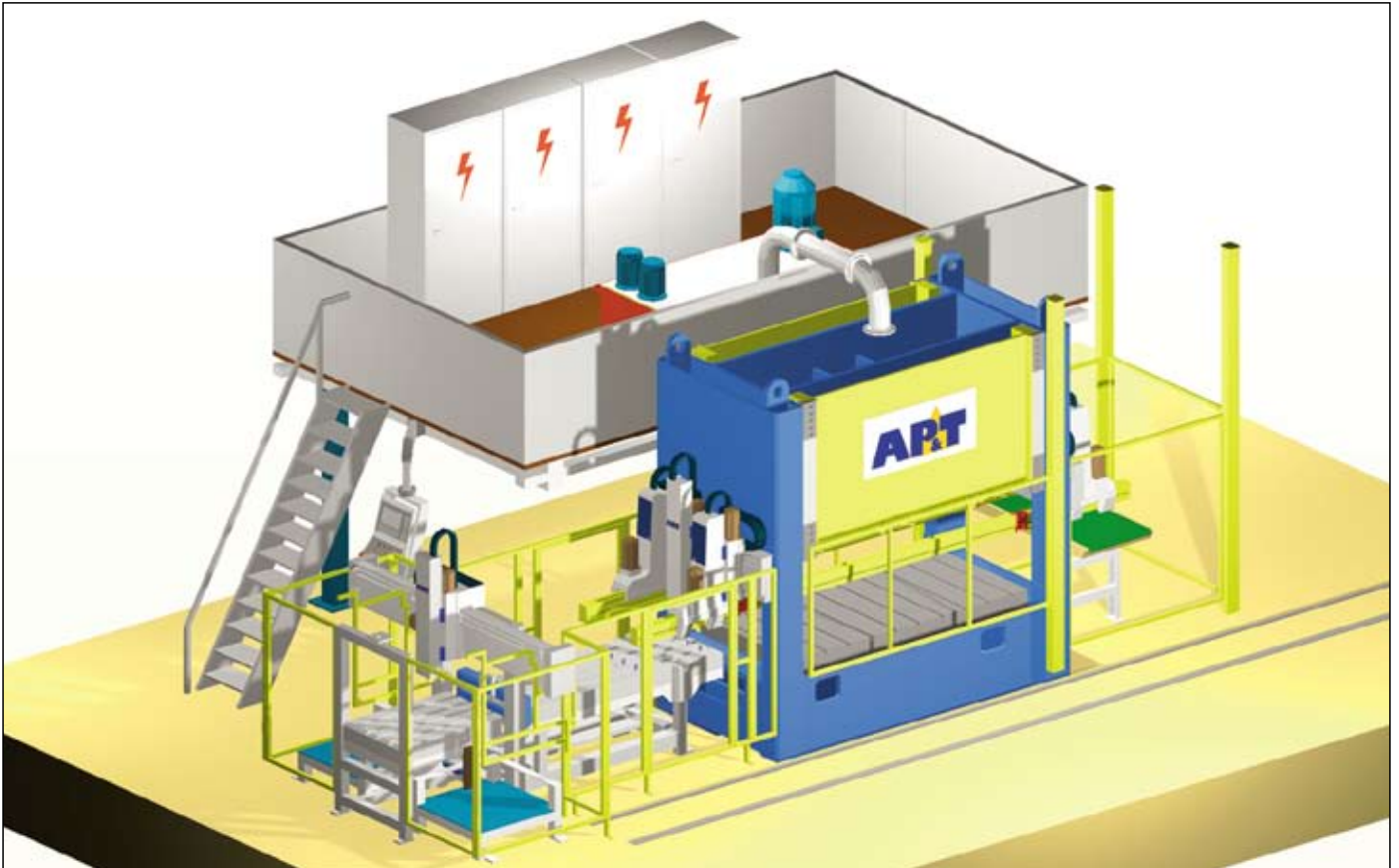

Automation on a single press

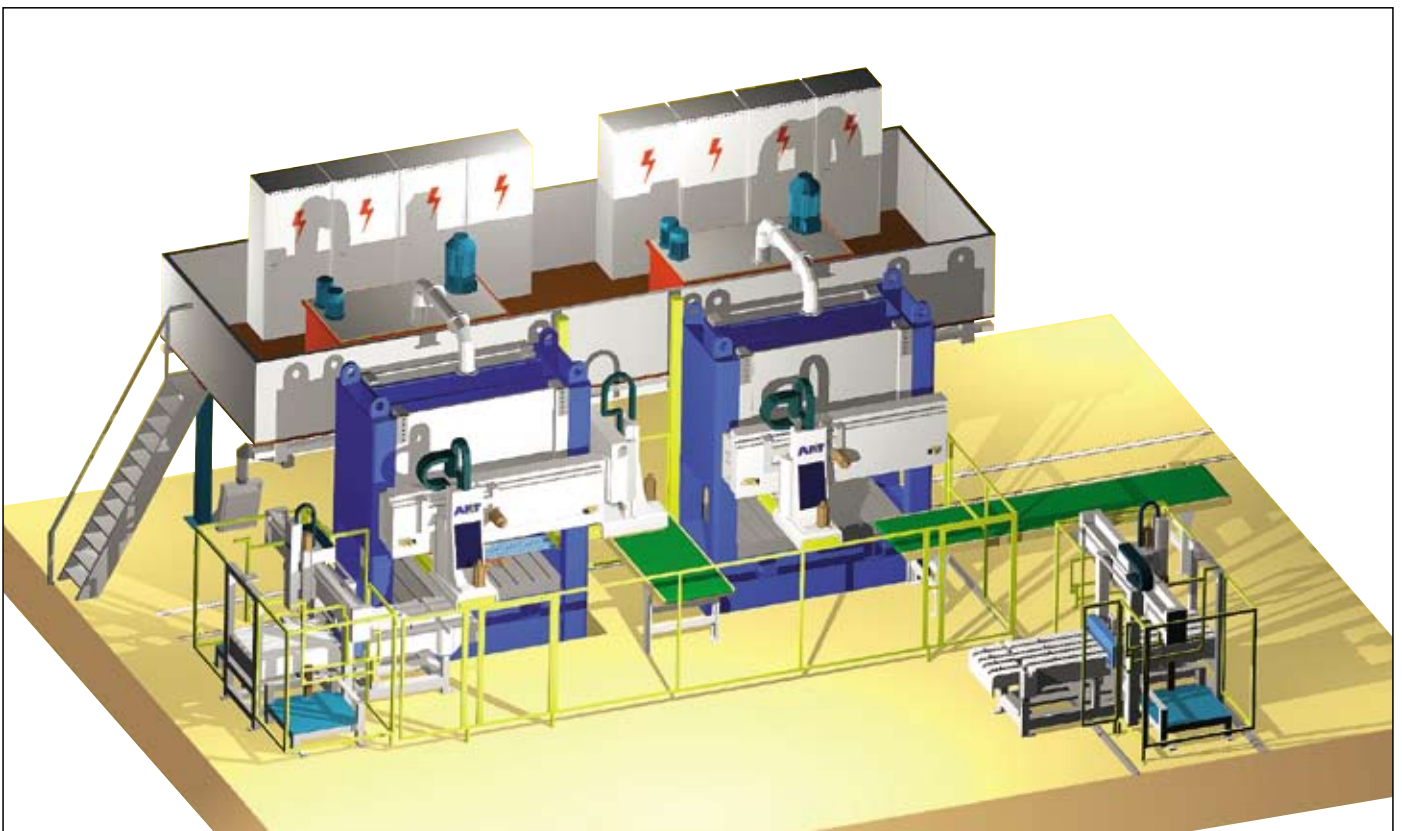

Automation on a two-press line

AP&T » Box 208, Industrigatan 5, SE-514 24 Tranemo, Sweden » Phone +46 325 66 18 00
Fax +46 325 66 18 88 » E-mail info@aptgroup.com » Internet aptgroup.com