

Pressure Dome for Hydroforming

Makes the impossible possible!

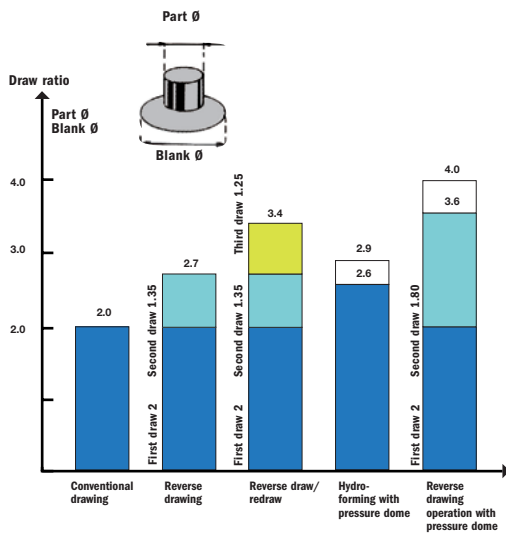



Hydroforming with pressure dome (I)

This technique makes the impossible possible - at a lower cost! The easily fitted pressure dome further enhances the versatility of the AP&T press. It provides the ability to produce parts in one operation that were either impossible by conventional means, or may have required up to six operations. This type of forming technique also provides the ideal method for producing parts with complex shapes or where draw ratios of up to 1:2.9 are required.

The pressure dome is a complete tooling system and can be fitted to and removed from the press in a matter of minutes. Units for blank diameters of 250 and 400 mm are manufactured as standard. Other sizes are available on request. The AP&T pressure dome technique is a well-proven and highly successful process.

Working Principle

Hydroforming with pressure dome is achieved by creating pressure (80 – 1,000 kp/cm²) in a medium (fluid) in an enclosed chamber. This pressure works against the penetrating punch, forming the sheet against the punch.

The slide moves down and closes the tooling then switches to pressing mode. The blank holder ring meets the draw ring and the blank is clamped between these two. The triple cylinder acts as a blank holding cylinder and is programmed with the force required to hold the blank flat to minimize wrinkles.

The slide continues downwards and presses the triple cylinder (blank holder) upwards. The punch draws the blank down in the pressure chamber. The blank is formed around the punch through the counter pressure that builds up in the fluid. The process utilizes the characteristic of the fluid always applying pressure perpendicular to the material.

During the process the pressure medium (fluid) attempts to penetrate between the sheet and the draw ring. This means that the sheet floats on the pressure medium and does not come into contact with the radius of the draw ring. The sheet component receives a very high surface finish, which is free of scratches and other processing damage. This unique advantage is difficult to achieve using traditional methods.

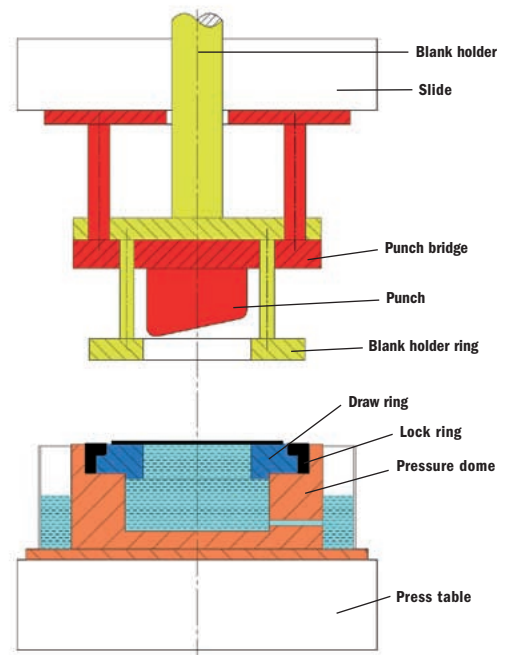
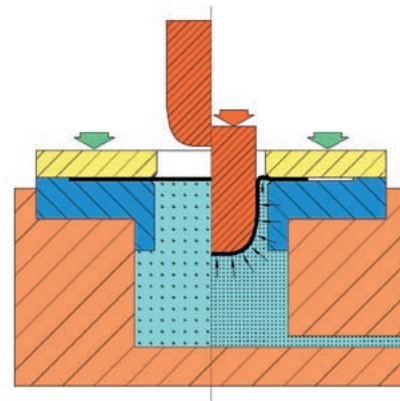

WHERE? AND WHEN?

This technique can be used to great advantage:

- When close tolerances and fine surface finishes are required.
- On small batch quantities for which inexpensive tooling can be made.
- For prototype and research work.
- For complex and hard-to-form parts.
- For parts with extremely high draw ratio (1:2.7-3.6).
- When there can be problems with intermediate annealings.

Tooling Design

Tooling for this forming technique is simple, consisting of a punch, draw ring and blank holder ring. Criteria for selecting the quality of the tool steel for manufacturing tools are the same as when producing conventional forming tools.

The draw ring is locked into the top of the pressure dome and is fitted with an o-ring. The punch and blank holder are supported by the punch bridge from above. The punch is fastened to the main slide by a center bolt tightened from the outside through a remote control linkage. The blank holder ring is fastened to the punch bridge by threaded lifting pins.

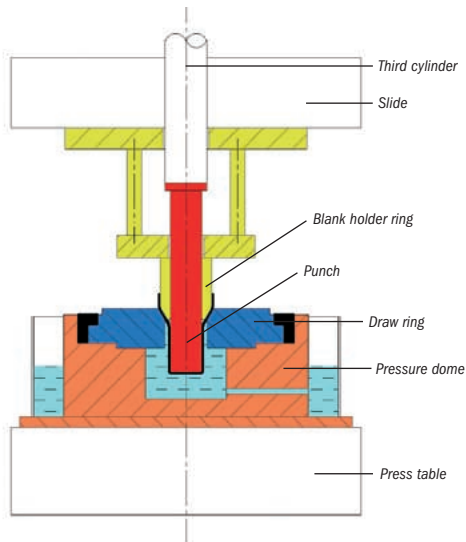
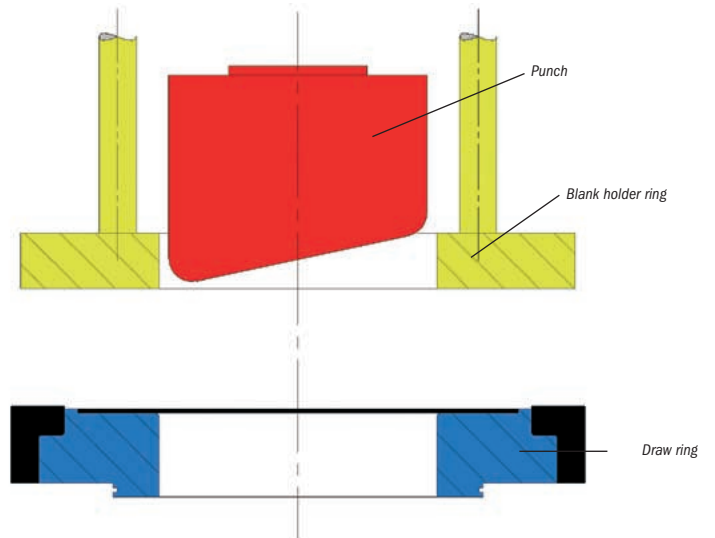

Redraw Operation (II)

The redraw operation greatly improves the draw ratio between the first and second draws. Ratios up to 1:1.9 in a secondary redraw (i.e. combined ratio up to 5.0) have been achieved.

This method also ensures excellent surface finishes.



Reverse Drawing Operation (III)

This technique combines a conventional first draw with reverse drawing into the dome. This enables very high draw ratios (1:3.6-4.0) to be produced and also hard-to-form shapes, such as very long cones can be formed.

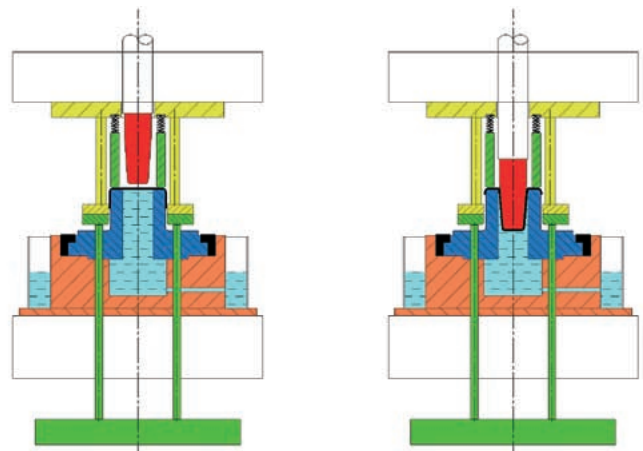
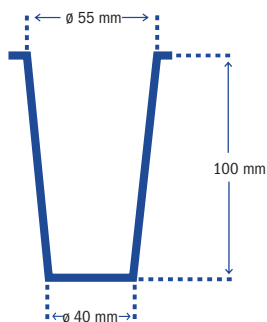

Conventional Forming

Requires 6 operations and 6 toolings.



Hydroforming with Pressure Dome

Requires only 1 operation and 1 tooling.

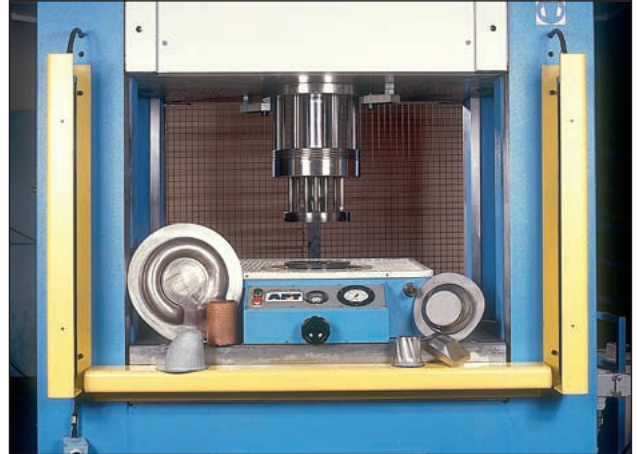
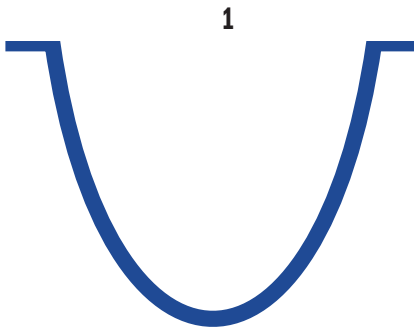

Part	Dimensions L x W x H	Material	Thickness	Press size	Op
1	Ø 90 H=100	Stainless Steel	0.6 mm	1,500 kN	1
2	Ø 130 H=130	Steel	1.0 mm	2,500 kN	1
3	Ø 400 H=60	Stainless Steel	4.0 mm	5,000 kN	1
4	Ø 180 H=100	Steel	1.0 mm	2,000 kN	1
5	Ø 170 H=60	Stainless Steel	0.7 mm	2,000 kN	1
6	115x140x3,100	Copper	0.7 mm	2,000 kN	1
7	Ø 110 H=145	Stainless Steel	0.6 mm	2,000 kN	1